

5

Understanding the Wire EDM Process

Accuracy and Tolerances

Wire EDM is extremely accurate. Many machines move in increments of 40 millionths of an inch (.00004") (.001 mm), some in 10 millionths of an inch (.00001") (.00025 mm), and others even in 4 millionths of an inch (.000004") (.0001 mm).

Machines can achieve accuracies of +/- .0001" (.0025 mm); however, skim cuts need to be made to obtain such tolerances. See Figure 5:1.

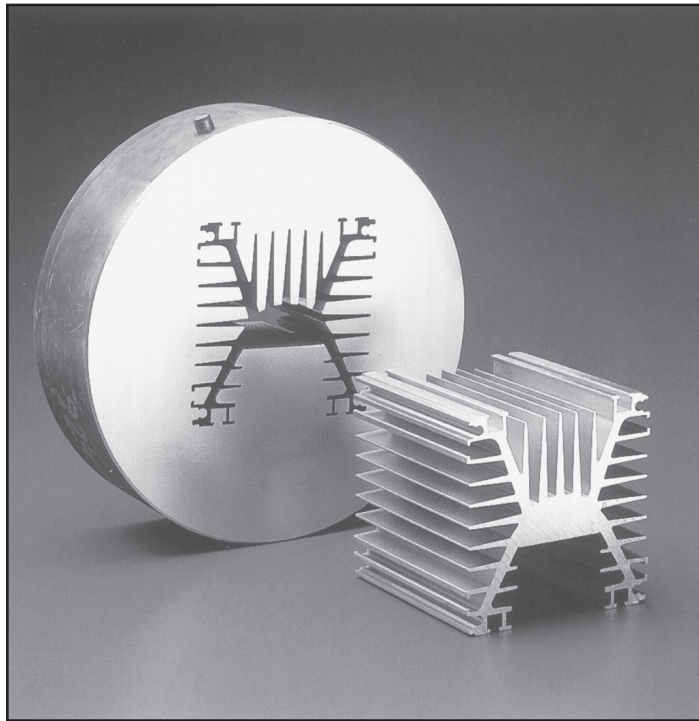

Courtesy Agie

Figure 5:1

Precision Wire EDMing

Finishes

Extremely fine finishes of 12 rms can be produced with wire EDM. Wire EDM produces an excellent finish, even in the so-called "rough cut." Customers are often amazed when shown the fine finish of a single-pass cut.

This fine finish is present, even after very large parts are cut, as in Figure 5:2. In other cutting operations, such as lasers and abrasive water jet, the larger the part, the rougher the finish. Wire EDM produces a smooth finish because the wire electrode goes through the entire part, and spark erosion occurs along the entire wire electrode.

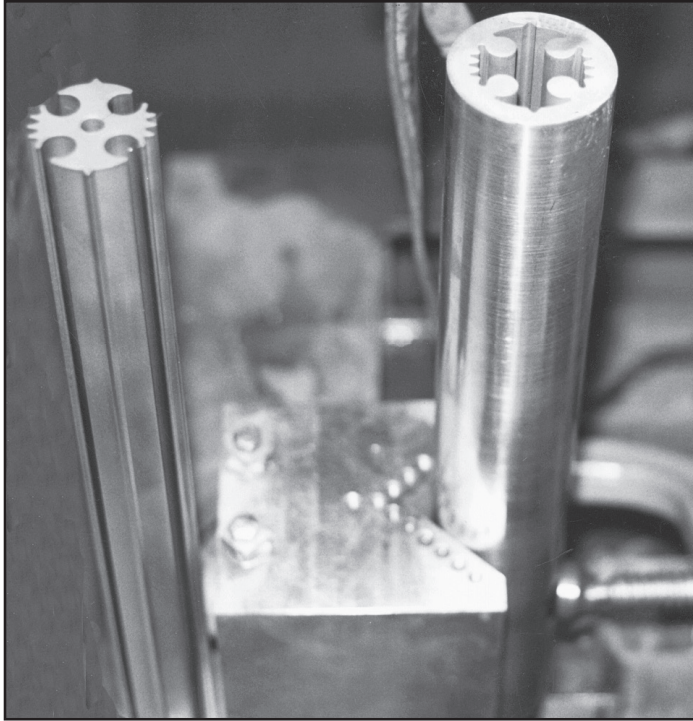

Figure 5:2

Showpiece: 16 Inches (406 mm) Tall—Cut at Reliable EDM
(Reliable Can Wire EDM Parts Up to 64" (1626 mm) Tall)

Wire Path

A. Wire Kerf

The wire never contacts the workpiece. If the wire would contact the workpiece, there would be a short circuit and no cutting would occur. The wire electrode cuts by means of spark erosion, thereby leaving a path slightly larger than the wire. A commonly used wire, .012" (.30 mm), usually creates a .016" (.41 mm) kerf, as shown in Figure 5:3. Thinner wires have smaller kerfs.

B. Corners and Radii

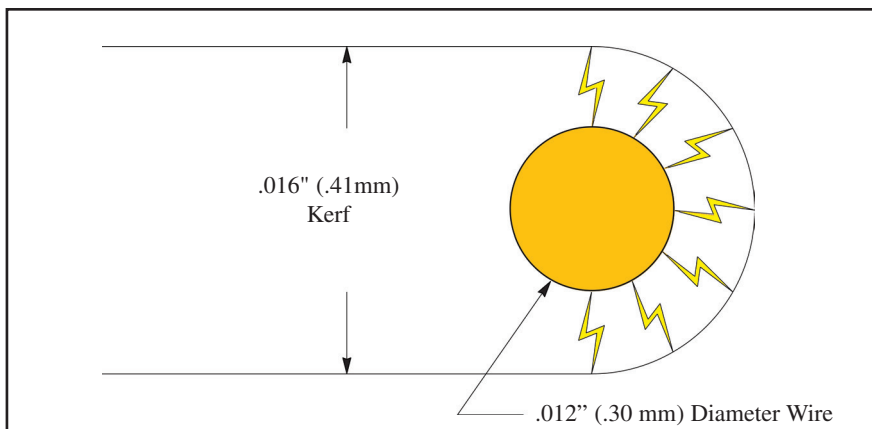

Figure 5:3
Wire Kerf

When the wire turns a corner, it can produce a sharp edge on the outside corner, but it will always leave a small radius on the inside corner, as demonstrated in Figure 5:4. The size of this radius is determined by the wire diameter plus the spark gap.

To produce very sharp outside corners, skim cuts are made. Having small corner radii on the outside corners can prevent the need for skim cuts; this also reduces wire EDM costs. In stamping dies, sharp corners usually wear first, so a small outside radius is preferable.

The minimum inside radius for .012" (.30 mm) wire is .0063" (.016 mm), and the minimum radius for .010" wire (.25 mm) is .0053" (.13 mm). These small radii are achieved by skimming. Smaller radii are possible with thinner wire; however, most work is done with thicker wires because thinner wire cuts slower.

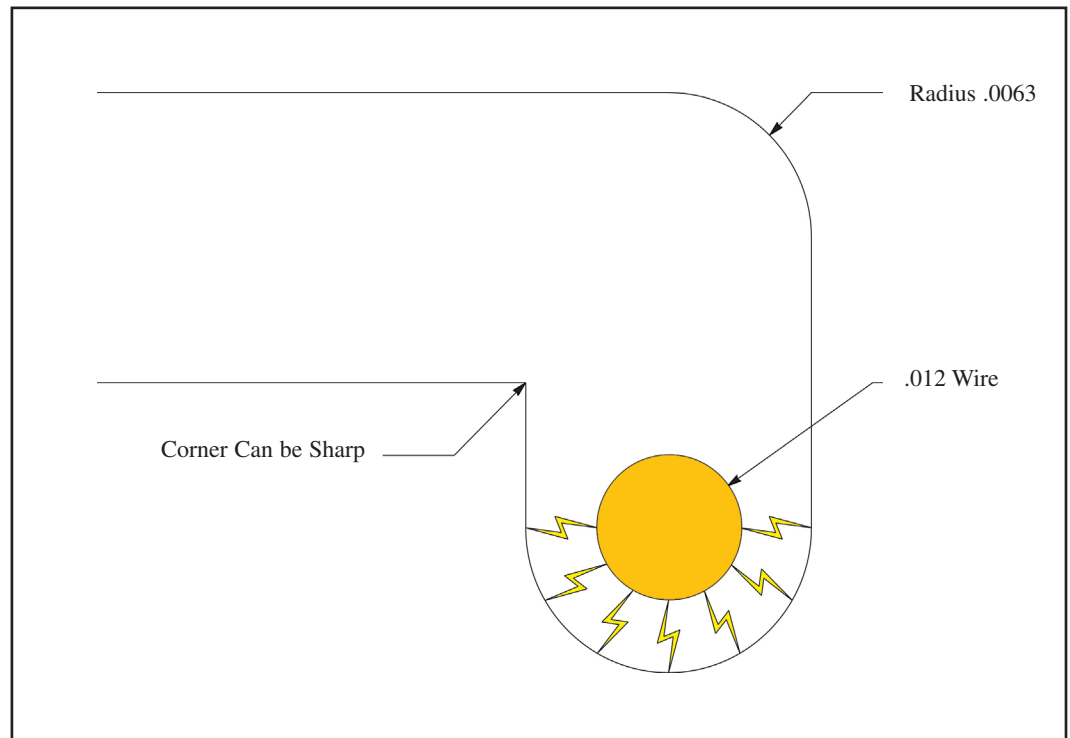

Figure 5:4

Inside and Outside Corners

Skim Cutting

For most jobs, the initial cut is sufficient for both finish and accuracy. However, for precision parts, skim cuts achieve greater accuracy and a finer finish. There are three main reasons for skim cuts:

- Barreling effect and wire trail-off
- Metal movement
- Finishes and accuracy

A. Barreling Effect and Wire Trail-Off

There is a .002" to .003" (.050-.076 mm) gap between the wire and the workpiece. (Gap is determined by the intensity of the spark energy.) In this gap, a controlled localized eruption takes place. The force of the spark and the gases trying to escape causes a slight barreling. On thick workpieces, this barreling causes the center to be slightly hollow. See Figure 5:5.

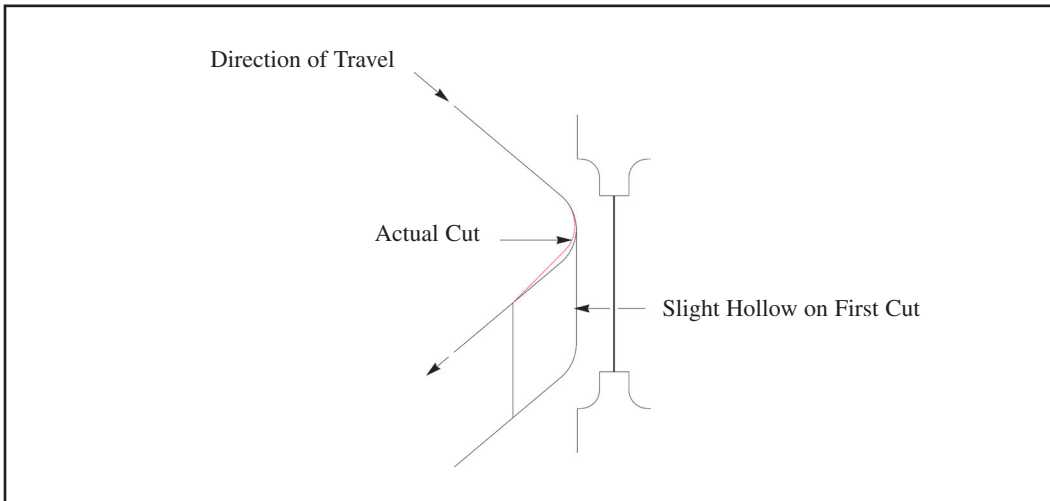

Figure 5:5

First Cut Corner Conditions

When cutting sharp corners, the wire dwells longer by the inside radius, causing a slight overcut; on the outside radius, it speeds, leaving a slight undercut, as illustrated in Figure 5:6. That is why most new machines have a slow down program for corner cutting. To achieve maximum corner profiles; however, skim cutting is recommended.

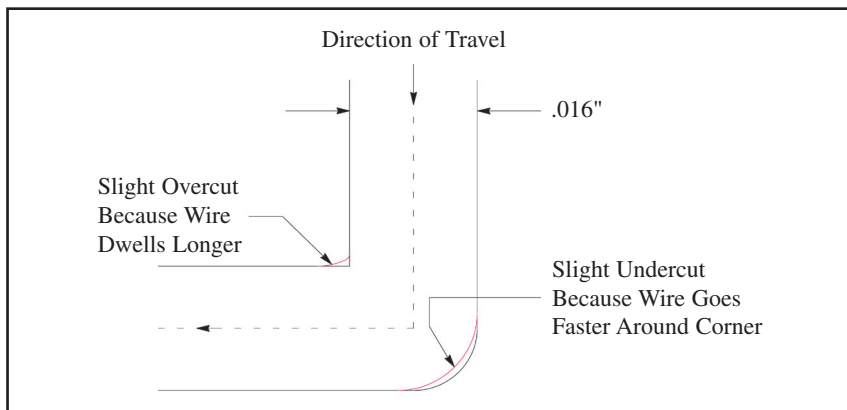

Figure 5:6

Skim Cutting is Used for Very Close Tolerances.

A trail-off is produced when the machine cuts a corner. A slight amount of material is left behind for a short distance before the wire returns to its programmed path. For most jobs, this slight undercut is negligible.

The sharper the corner, the greater the overcut and undercut. The accuracy of the part determines the need for skim cutting. To avoid most of this barreling effect and wire trail-off, some wire EDM machines automatically slow down in corner cutting. Nevertheless, high precision parts still require skim cuts.

B. Metal Movement

Even though metal has been stress relieved, it may move after the part has been cut with wire EDM because the stresses within the metal were not totally removed in stress relieving. If metal has moved due to inherent stresses, and the part requires to be precise, then skim cuts are used to bring the part into tolerance. The accuracies called for by the print determine the number of skim cuts.

C. Finishes and Accuracy

First cuts produce a fine finish; however, sometimes a finer finish and greater accuracies are required. To accomplish this, skim cuts are used. See Figure 5:7 for a general view of the various finishes that can be produced with wire EDM. (Some machines produce different results.)

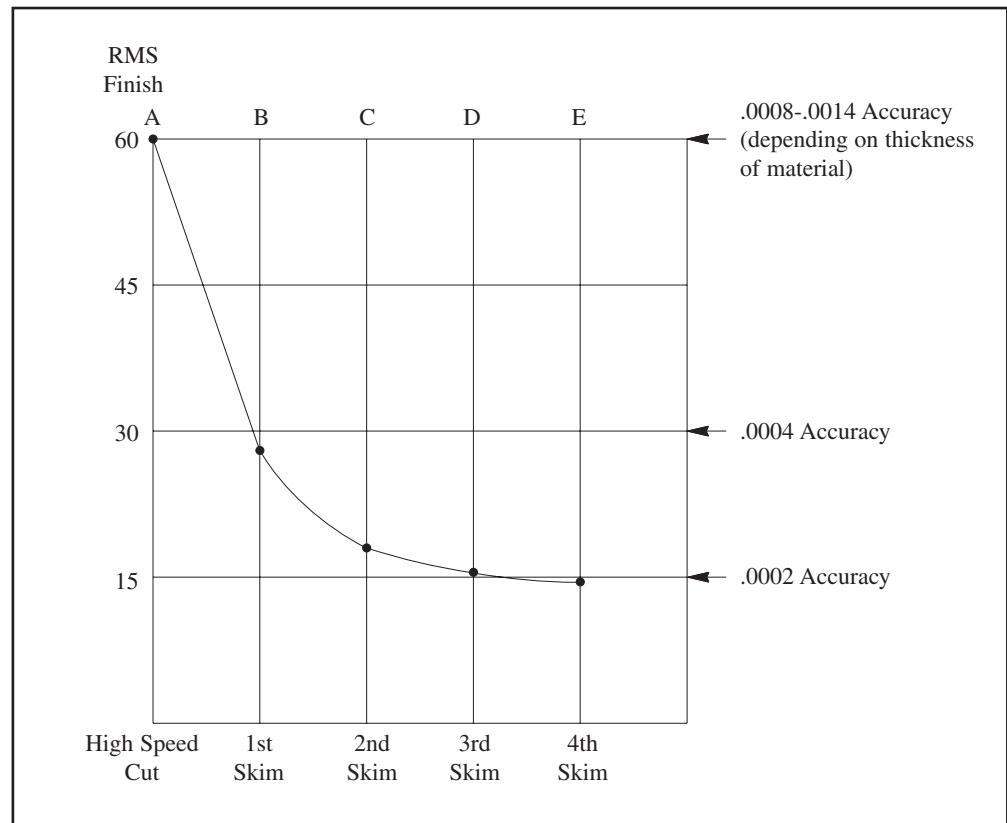

Figure 5:7

Approximate Accuracies and Finishes

Cut A—For most jobs, this finish and accuracy are more than adequate.

Cuts B-E—Depending on accuracy and finish required, various skim cuts are performed.

Skim cutting produces fine finishes because less energy is applied to the wire which creates smaller sparks and thus smaller cavities. These small sparks produce extremely fine finishes, and on some machines mirror finishes.

Carbide

Tungsten carbide, third in hardness to diamond and boron carbide, is an extremely difficult material to machine. Except for diamond cutting tools and diamond impregnated grinding wheels, EDM presents the only practical method to machine this hardened material.

To bind tungsten carbide when it is sintered, cobalt is added. The amount of cobalt, from 6 to 15 percent, determines the hardness and toughness of the carbide. The electrical conductivity of cobalt exceeds that of tungsten, so EDM erodes the cobalt binder in tungsten carbide. The carbide granules fall out of the compound during cutting, so the amount of cobalt binder determines the wire EDM speed, and the energy applied during the cutting determines the depth of binder that is removed.

When cutting carbide on certain wire EDM machines, the initial first cut can cause surface micro-cracks. To eliminate them, skim cuts are used. However, at our company, Reliable EDM, we have repeatedly cut carbide parts with a single cut. When precision carbide parts are needed, then skim cuts are used.

Some older wire EDM machines used capacitors. Since these machines applied more energy into the cut, there was a greater danger for surface micro-cracking. Then DC power supply machines without capacitors were introduced, and this helped in producing less surface damage when cutting carbide.

Today, many machines come equipped with AC power supplies. These machines are especially beneficial when cutting carbide in that they produce smaller heat-affected zones and cause less cobalt depletion than DC power-supplied machines.

To eliminate any danger from micro-cracking and to produce the best surface edge for stamping, it is a good practice to use sufficient skim cuts when EDMing high-precision blanking carbide dies. Studies show that careful skimming greatly improves carbide surface quality. Durability tests prove that an initial fast cut and fast skimming cuts produce very accurate high-performance dies.

Polycrystalline Diamond

The introduction of polycrystalline diamond (PCD) on a tungsten carbide substrate has greatly increased cutting efficiency. PCD is a man-made diamond crystal that is sintered with cobalt at very high temperatures and under great pressure. The tungsten substrate provides support for the thin diamond layer.

The cobalt in PCD does not act as a binder, but rather as a catalyst for the

diamond crystals. In addition, the electrical conductivity of the cobalt allows PCD to be EDMed. When PCD is EDMed, only the cobalt between the diamond's crystals is being EDMed.

EDMing PCD, like EDMing carbide, is much slower than cutting steel. Cutting speed for PCD depends upon the amount of cobalt that has been sintered with the diamond crystals and the particle size of PCD. Large particles of PCD require very high open voltage for it to be cut. Also, some power supplies cut PCD better than others.

Ceramics

Ceramics are poor conductors of electricity. However, certain ceramics are formulated to be cut with wire EDM.

Flushing

Flushing is an important factor in cutting efficiently with wire EDM. Flushing pressure is produced from both the top and bottom flushing nozzles. See Figure 5:8. The pressurized deionized fluid aids in spark production and in eroded metal-particle removal.

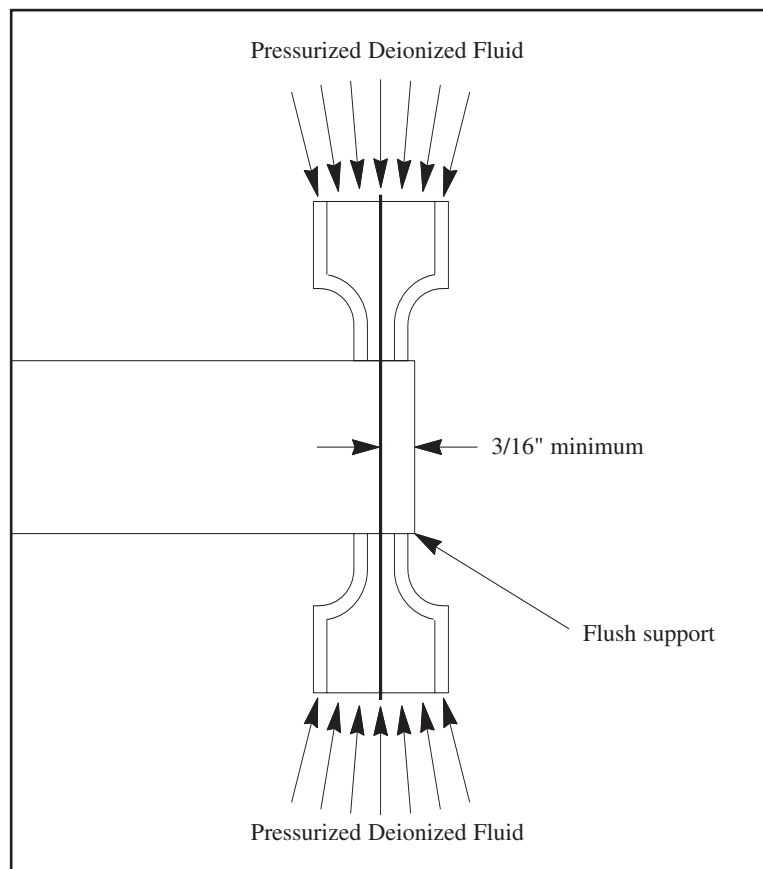

Figure 5:8

Ideal Flushing Conditions

Sometimes, the flushing nozzle may extend beyond the edge of a workpiece, as shown in Figure 5:9. When this occurs, flushing pressure is lost, and this can cause wire breakage and part inaccuracy. To avoid wire breakage in such cases, a lower spark energy is used which slows the machining process. To avoid losing flushing pressure, it is advisable, if possible, to leave at least 3/16" (5 mm) of material to support the flushing nozzles.

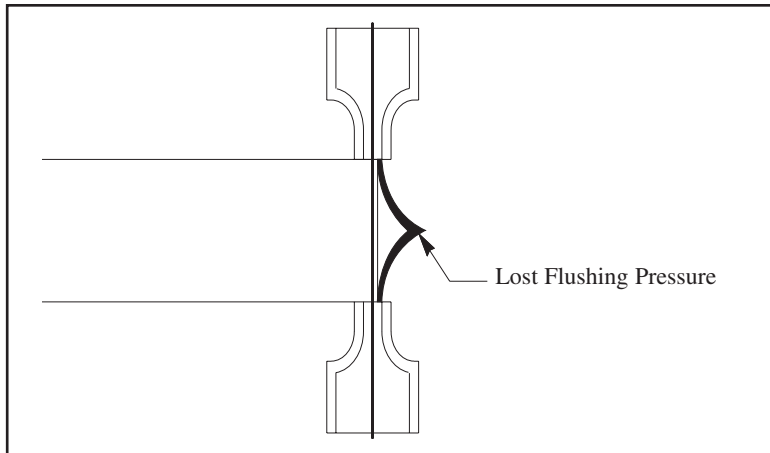

Figure 5:9

Poor Flushing Conditions

Cutting Speed

Speed is rated by the square inches of material that are cut in one hour. Manufacturers rate their equipment under ideal conditions, usually 2 1/4 inch (57 mm) thick D2 hardened tool steel under perfect flushing conditions. However, differences in thicknesses, materials, and required accuracies can greatly alter the speeds of EDM machines.

Cutting speed varies according to the conductivity and the melting properties of materials. For example, aluminum, a good conductor with a low melting temperature, cuts much faster than steel.

On the other hand, carbide cuts much slower than steel. It is the binder, usually cobalt, that is melted away. When the cobalt is eroded, it causes the carbides to fall out. Various carbides machine at different speeds because of carbide grain size and the binder amount and type.

Impurities

Generally, impurities cause little difficulty; however, occasionally materials are received with non-conductive impurities. The wire electrode will either stall or pass around small non-conductive impurities, thereby causing possible streaks from raised or indented surfaces.

When welded parts must be EDMed, one should use caution to make certain there is no slag within the weld. Tig welding is preferred for wire EDM.

Recast and Heat-Affected Zones

The EDM process uses heat from electrical sparks to cut the material. The sparks create a heat-affected zone that contains a thin layer of recast, also called "white layer." The depth of the heat-affected zone and recast depends upon the power, type of power supply, and the number of skim cuts.

The recast contains a layer of unexpelled molten material. When skim cuts are used, much less energy is applied to the surface. This greatly reduces and practically eliminates the recast layer.

On older wire EDM machines, the heat-affected zones and recast were much more of a problem. Also, the recast and heat-affected zones of ram EDM are much greater when roughing because more energy can be used than with wire EDM.

Many of today's wire EDM machines have reduced this problem of recast and heat-affected zones. Our company, Reliable EDM, is a wire EDM job shop that has done work for well over 500 companies, including aerospace companies. We have wire EDMed thousands of jobs and cut all sorts of materials, including carbide and high-alloy steels. We have had practically no negative results from recast and heat-affected zones. Most work is done with just one cut. For precision parts, skim cuts are used.

Newer machines now come equipped with anti-electrolysis power supplies, also called AC power supplies. These power supplies greatly reduce the recast and heat-affected zones. On some machines, the heat-affected zone for the first cut is .0015" (038 mm), on the first skim cut it is .0003" (.0076 mm), and on the second skim cut it is .0001" (.0025 mm).

For years, the recast and heat-affected zones have been a concern for the aerospace and aircraft industry. With the improvement of power supplies, these industries increasingly accept work done with wire EDM.

AC Non-Electrolysis Power Supplies

Instead of cutting with DC (direct current), some machines cut with AC (alternating current). Cutting with AC allows more heat to be absorbed by the wire instead of the workpiece.

Since AC constantly reverses the polarity of the electrical current, it reduces the heat-affected zone and eliminates electrolysis. Electrolysis is the stray electrical current that occurs when cutting with wire EDM. For most purposes, electrolysis does not have any significant effect on the material. However, the elimination of electrolysis is particularly beneficial when cutting precision carbide dies in that it reduces cobalt depletion.

When titanium is cut with a DC power supply, there is a blue color where the material was cut. This blue line is not caused by heat, as some suspect, but by

electrolysis. This effect is not generally detrimental to the material. However, AC power supplies eliminate this line.

Like AC power supply, the AE (anti-electrolysis) or EF (electrolysis-free) power supplies improve the surface finish of parts by reducing rust and oxidizing effects of wire EDM. Also, less cobalt binder depletion occurs when cutting carbide, and it eliminates the production of blue lines when cutting titanium. AC and non-electrolysis power supplies definitely have advantages. See Figure 5:10 for comparison between anti-electrolysis and conventional machining.

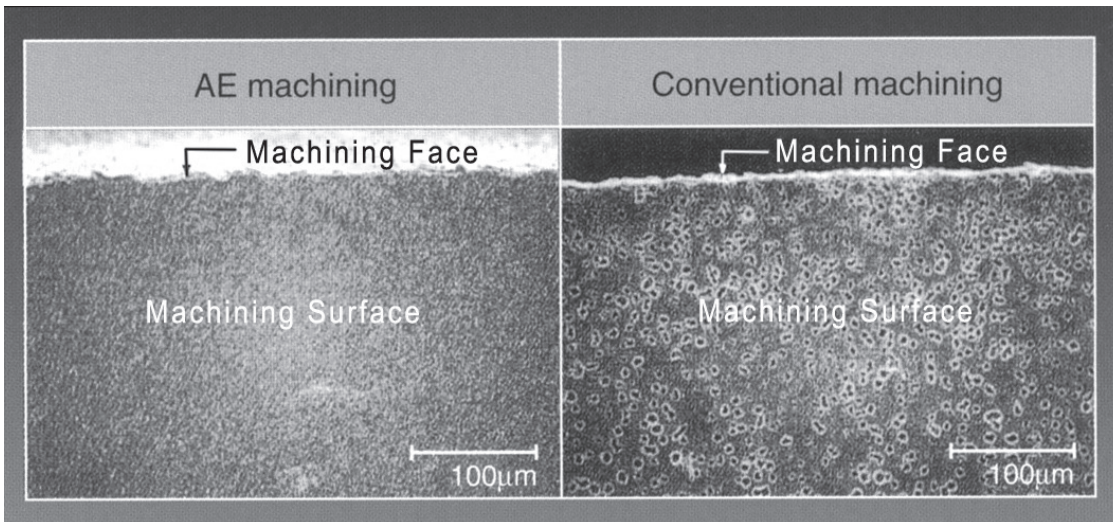

Figure 5:10

Courtesy Mitsubishi

Anti-Electrolysis and Conventional Machining Surfaces Compared

Isolated Pitting

When doing mold work, the surface finish of the molds is extremely important. On certain materials, such as H-13 and S-7, pitting sometimes occurred when the steel was wire EDMed. However, pitting never occurred when cutting D2 steel. It was discovered that the chrome content of D2, which is 12%, was much higher than H-13—only 5% chrome, and S-7—only 3.25%. However, H-13 and S-7 are very popular mold steels.

The chrome content answered some of the problems, but not all. Sometimes when cutting H-13 and S-7, pitting did not occur. The question arose, "Why does pitting only occur occasionally?"

After further testing, it was discovered that magnetism was the reason for the pitting. On some occasions, even after the steel was thoroughly demagnetized, they found some pitting. Then it was discovered even the rails on the wire EDM machine, which could have residual magnetism, had an effect. One mold company found a solution by purchasing an instrument that measured magnetic induction (Gaussmeter). The company came to the conclusion that residual magnetism was the basic cause for pitting.

Heat-Treated Steels

Wire EDM will machine hard or soft steel. Materials requiring hardening are commonly heat treated before being cut with wire. By heat treating steel beforehand, it eliminates the distortions that can be created from heat-treating.

The decision to heat treat steel before or after is often determined by the required accuracy needed, or if machining must be done after wire EDMing.

Cutting Large Sections

Steels from mills have inherent stresses. Even hardened steel that has been tempered often has stresses remaining. For cutting small sections, the effect is negligible. However, for large sections when there is a danger of metal movement, it is advisable to remove some of the metal. By removing metal, it helps to reduce the possibility of metal movement. Workpiece accuracy is the determining factor if metal needs to be removed. See Figure 5:11.

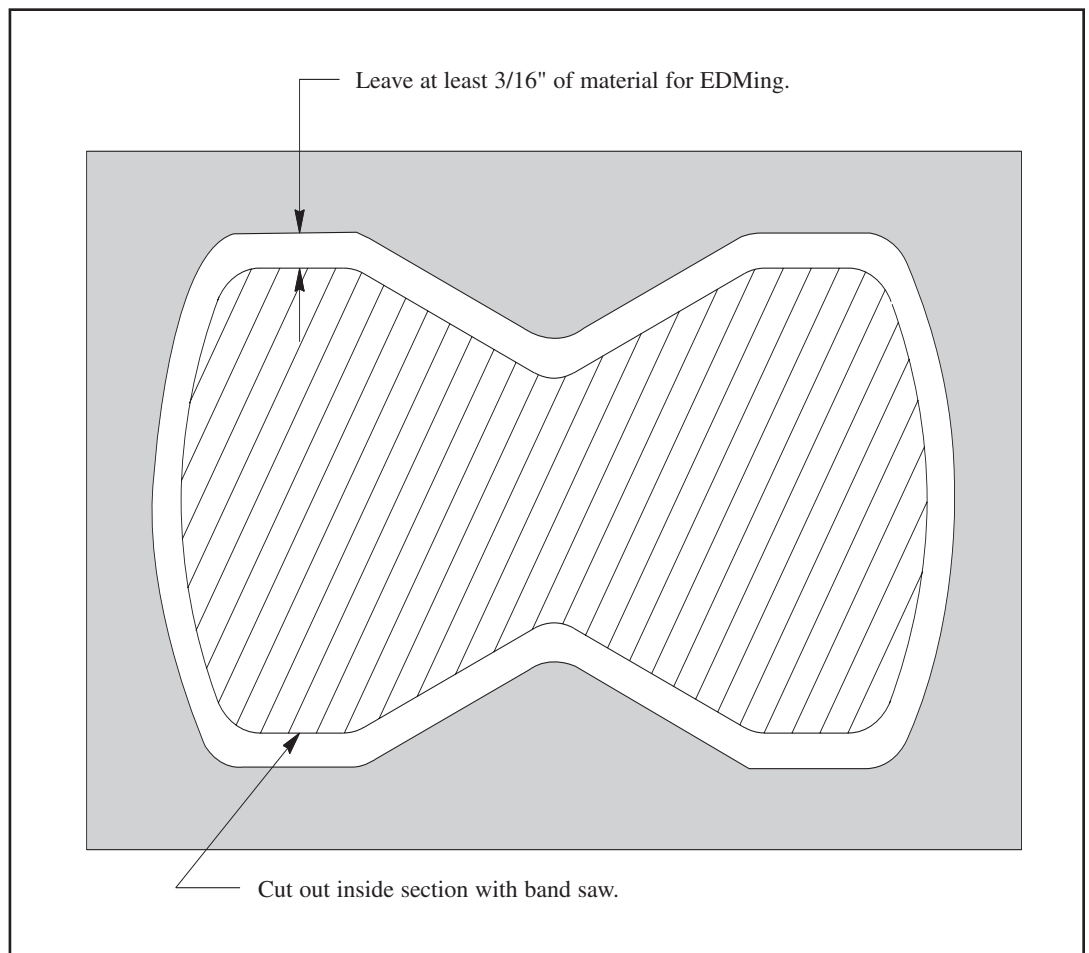

Figure 5:11

Removing Material to Reduce Stresses on Large Parts

Metal movement can also be reduced by cutting relieving slots with a band saw to connecting holes, as in Figure 5:12. Steel should be stress relieved before heat-treating to remove the stresses caused by milling, drilling, and grinding. After heat-treating, the tool steel should be double or triple drawn, including the non-deforming air hardening tool steels. Another method to remove stresses is to use cryogenics (deep freeze). The tool steel is hardened and tempered; then it is put into deep freeze and retempered.

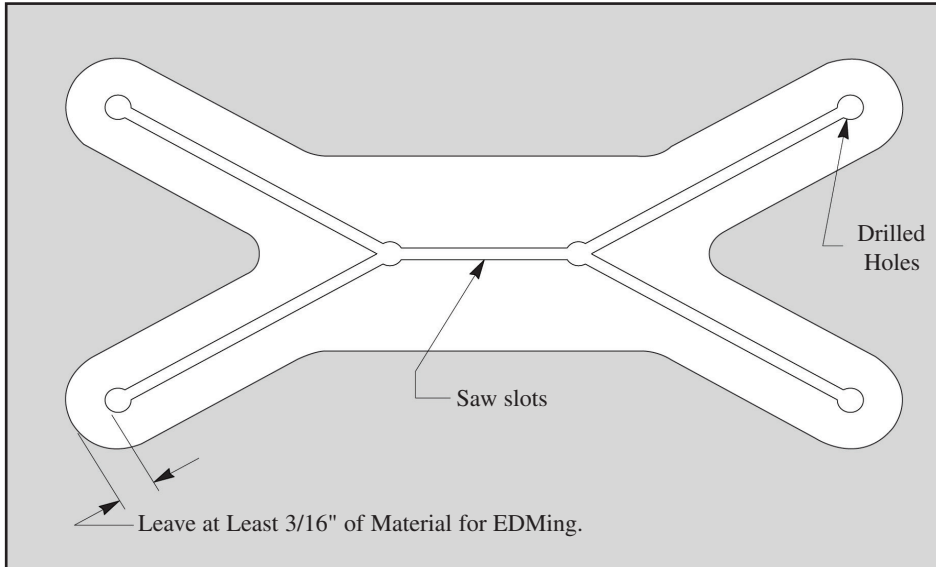

Figure 5:12

Using Saw Slots to Reduce Stresses on Large Parts

Cutting Sections from a Block

A. Leaving a Frame

When a section must be cut from a block of steel, a frame should be left around the workpiece to ensure accuracy and to reduce cost. At least 1/4 to 1/2" (6.5 to 13 mm) should be left around the part so that flush nozzles can efficiently remove the eroded particles and also support the part for clamping. See Figure 5:13.

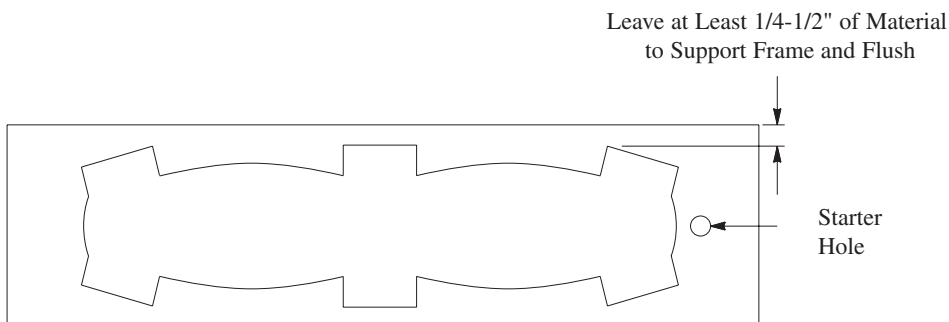

Figure 5:13

Support Part with Frame

B. Strength of Frame

Sufficient extra material needs to be left around the part. When the part is held in a fixture, the extra material will prevent the part from moving as it is being EDMed. Figure 5:14 demonstrates a weak support frame. While the part is being EDMed, the frame becomes weak, which can cause the part to move.

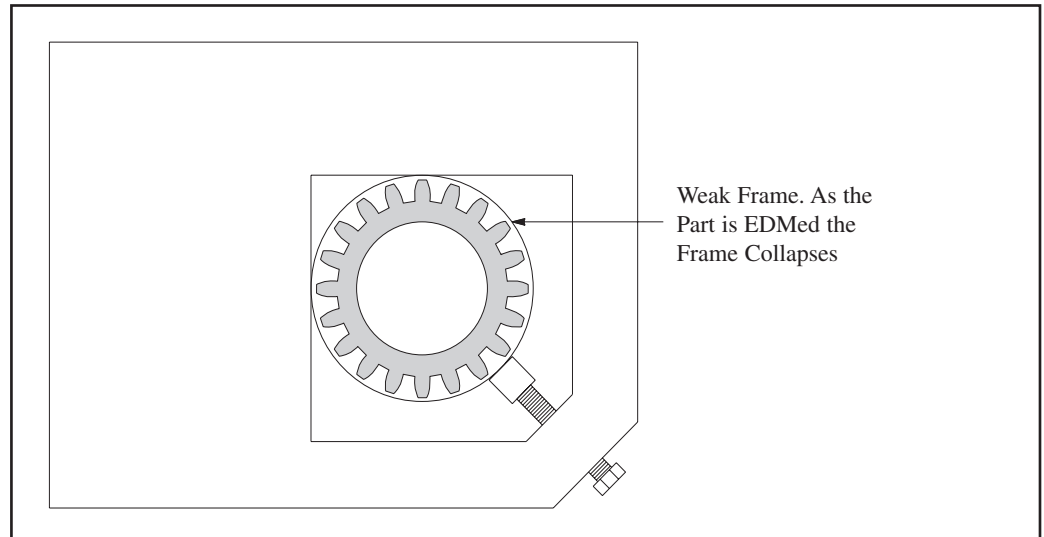

Figure 5:14
Improper Support Frame

C. Material for Clamping

For many parts, fixtures are used, as shown in the above illustration. However, for some parts provision should be made for clamping. See Figure 5:15.

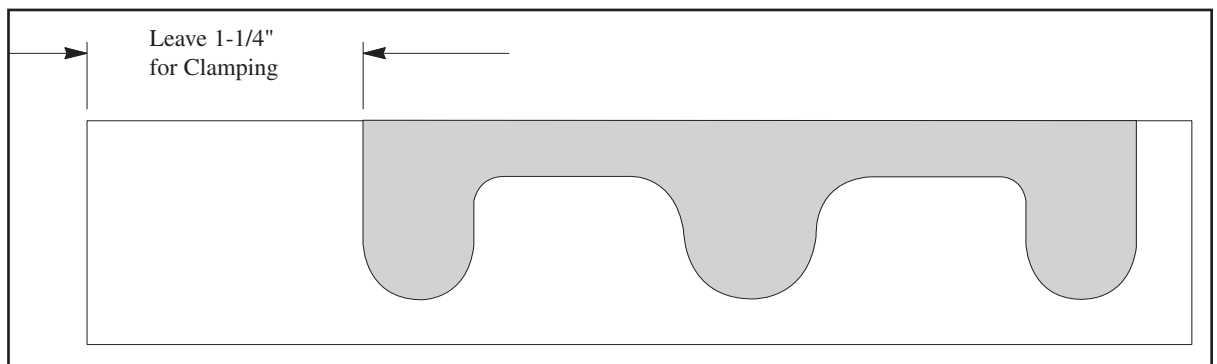

Figure 5:15
Extra material provided for clamping

Understanding the Wire EDM Process

The better understanding one gains of the wire EDM process, the more benefits one can obtain from this process. The next section covers how to reduce wire EDM costs.